

*de antonio*  
YACHTS



NEW **E23**

LAUNCHING 2024

# THE NEW FACE OF ELECTRIC NAVIGATION



The E23 is the brand's first 100% electric boat, the beginning of a new era. An innovative model, which concept is based on maximum efficiency. Its compact proportions with a catamaran architecture integrates a foil between its hulls, giving it unique emission-free sailing performance in its segment while offering a practical and comfortable space on deck, with a careful design all throughout details and finishes.

A model that combines cutting-edge technology and design. The new E23 has been chosen by the organization of the most important sailing competition in the world, to be the Official Electric Boat of the 37th Edition of the America's Cup, to be held in Barcelona in 2024.

---

*El E23 es el primer barco 100% eléctrico de la marca, el inicio de una nueva era. Un modelo innovador, que basa su concepto en la máxima eficiencia. Sus compactas proporciones con arquitectura de catamarán integrando un "foil" entre sus cascos, lo dotan de unas prestaciones de navegación sin emisiones únicas en su segmento al mismo tiempo que ofrece un práctico y confortable espacio en cubierta con un cuidado diseño en numerosos detalles y acabados.*

*Un modelo que aún tecnología y diseño de vanguardia. El nuevo E23 ha sido el elegido por la organización de la competición a vela más importante de mundo para ser el Barco Eléctrico Oficial de la 37ª Edición de la America's Cup que se celebrará en Barcelona en 2024.*

# TECHNICAL SPECIFICATIONS

**50kW/70HP**

POWER

**40 kWh**

BATTERY CAPACITY

**+30 Knots**

MAXIMUM SPEED

RANGE: 6 Knots 10h. **60 Miles** / 20 Knots 2h. **40 Miles**

CHARGING TIME: **1h 30'** with fast charger / **12h** with standard charger

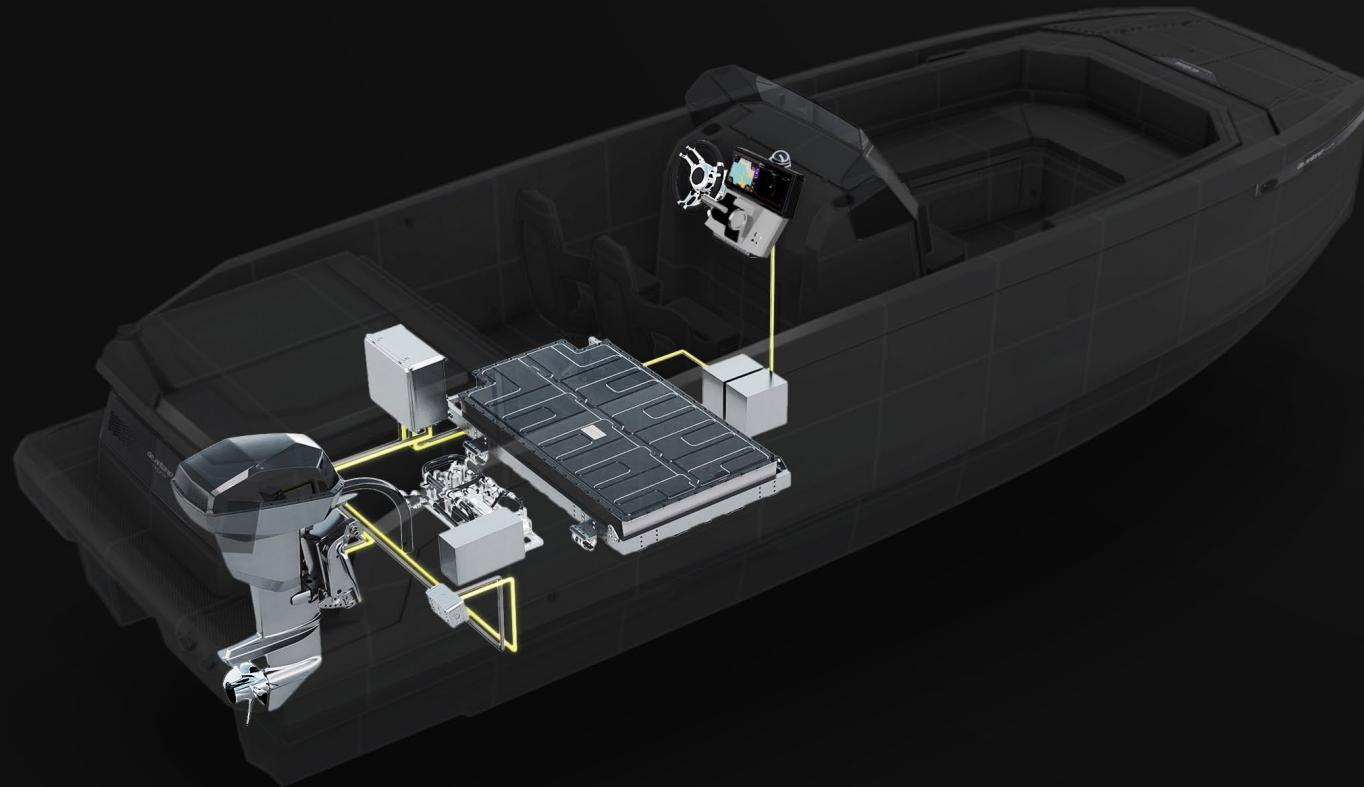

**7,20m**

OVERALL LENGTH

**6,40m**

WATERLINE LENGTH

**2,30m**

BEAM

**0,40m**

DRAFT (without engine)

**1.600Kg**

DISPLACEMENT

**55L**

WATER TANK

CONSTRUCTION: GRP with vinylester resin

FOIL: **6061** Casted alloy

# DECK LAYOUT



**DECK**  
*MAIN BASE LAYOUT*

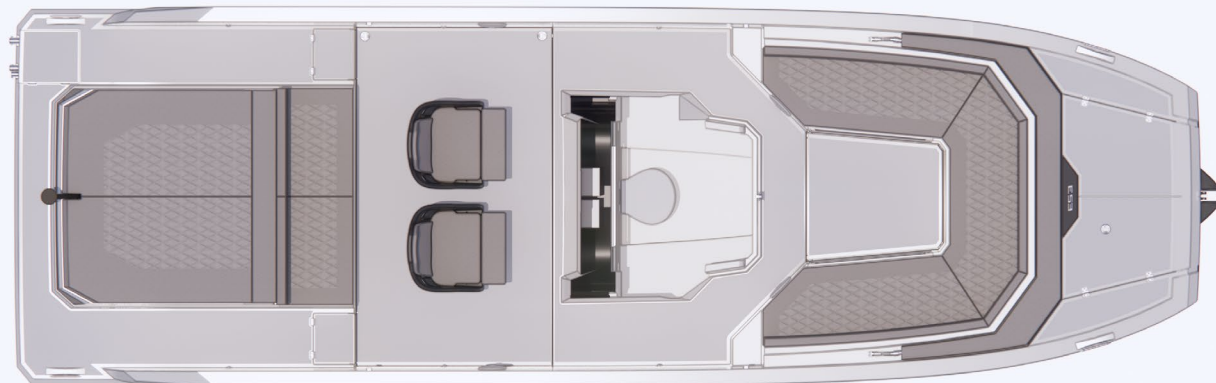

**DECK**  
*STORAGE CABIN WC OPTIONAL*

# BOW AREA

**BOW TABLE**  
*OPTIONAL*

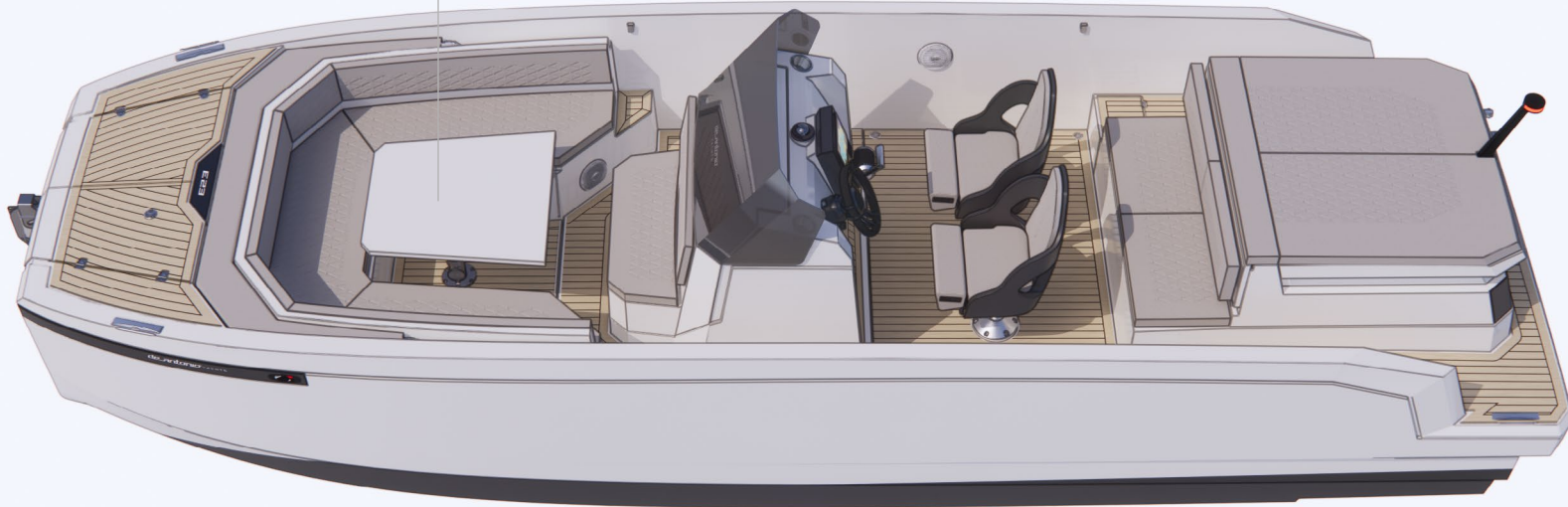

# BOW AREA

**BOW SOLARIUM  
MODE**

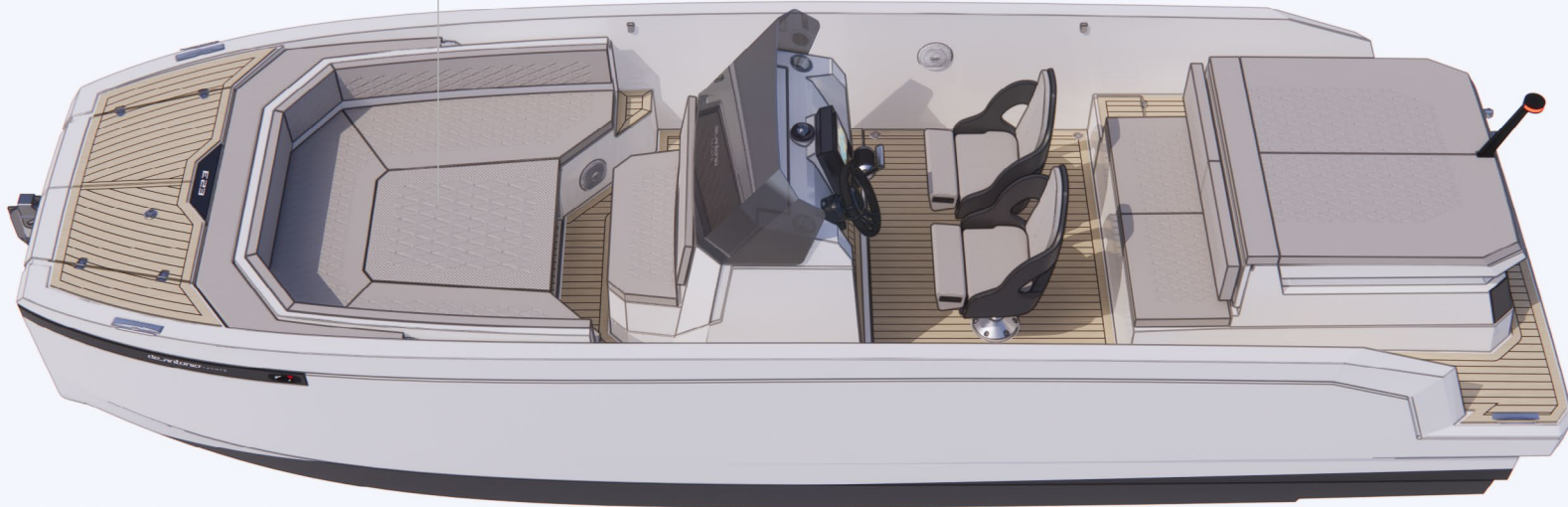

## BOW AREA



**LIDS**  
ANCHOR LOCKER

NEW **E23**

# BOW AREA

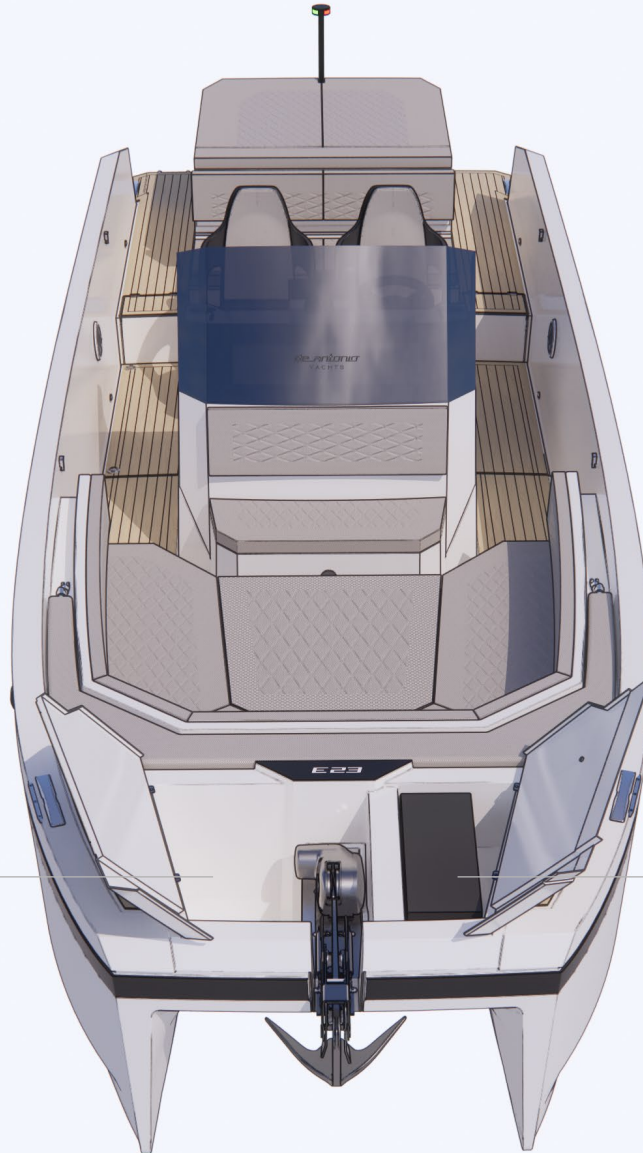

**ANCHOR POST  
LEWMAR  
OPTIONAL**

**STORAGE FOR 4  
FENDRES  
550X230X60**

NEW **E23**



## BOW AREA

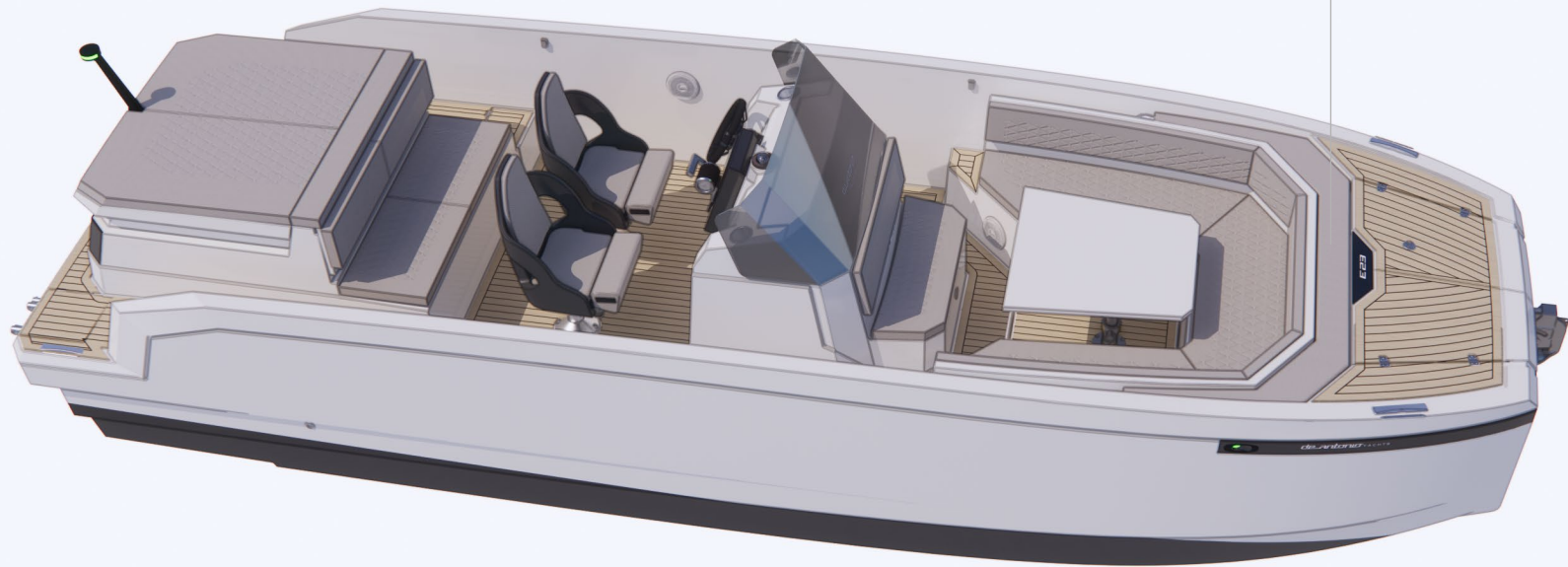

**SPACE FOR  
FOLDED SPRAY  
HOOD BARS/  
TEXTILE**

# BOW AREA

SPRAY HOOD  
OPTIONAL

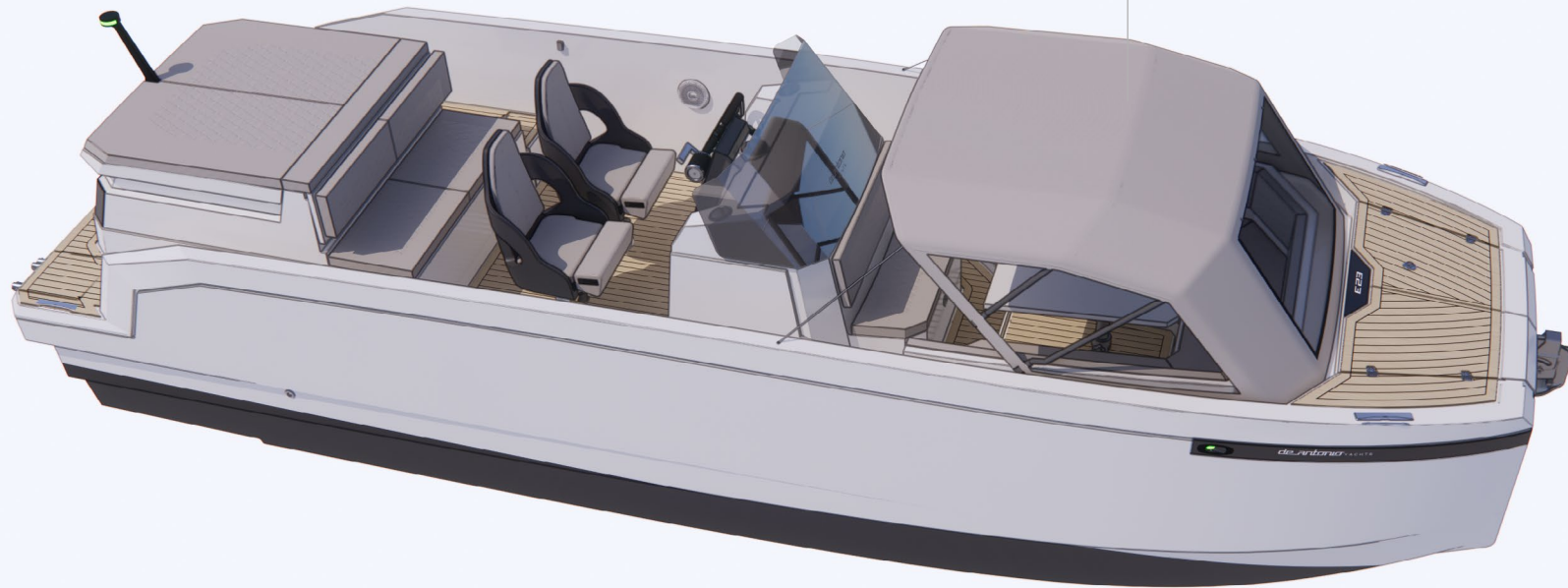

NEW **E23**

# BATTERY COMPARTMENT

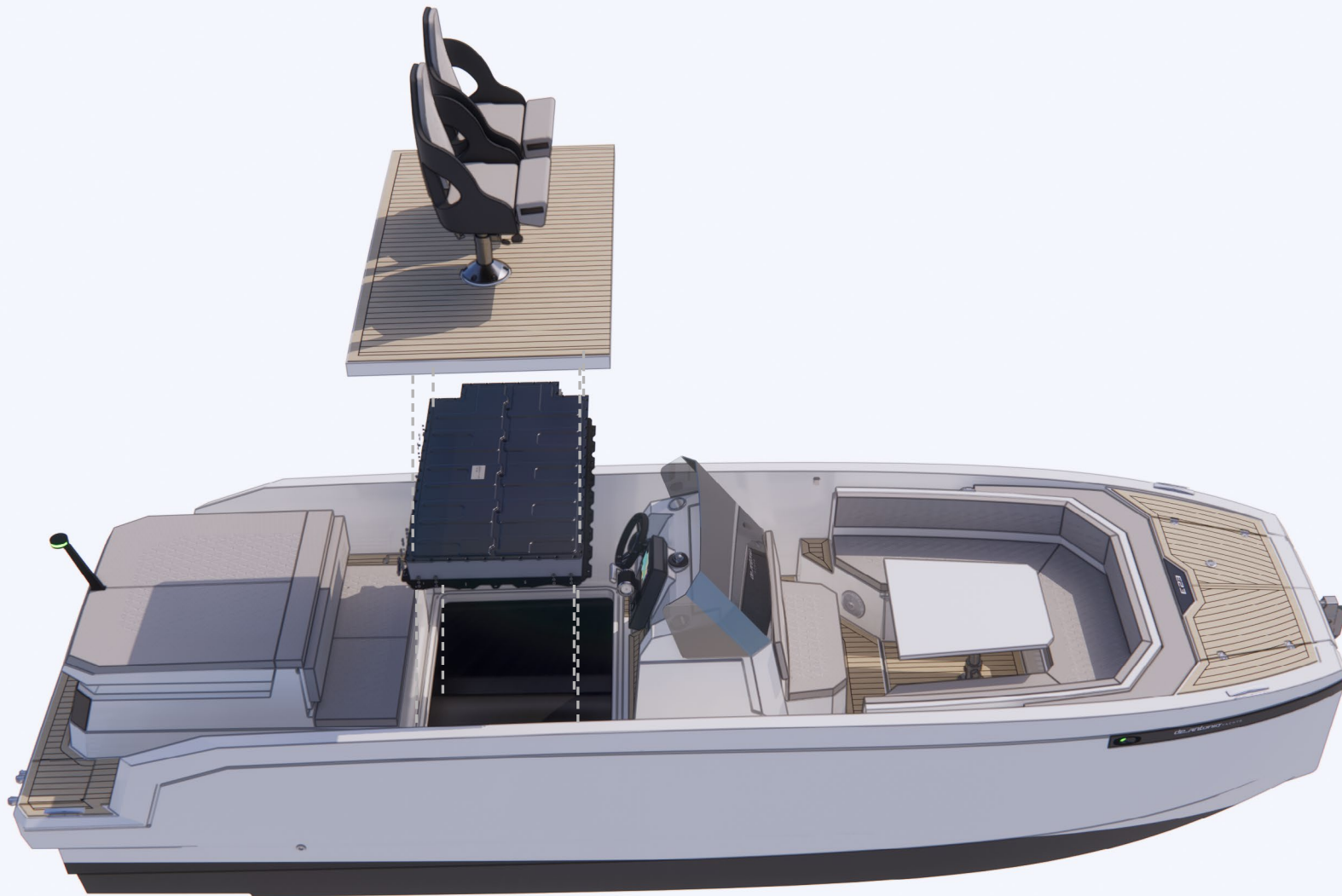

NEW **E23**

# STORAGE CABIN



**CHEMICAL WC**  
*OPTIONAL*

**STORAGE SPACE**

# STERN AREA

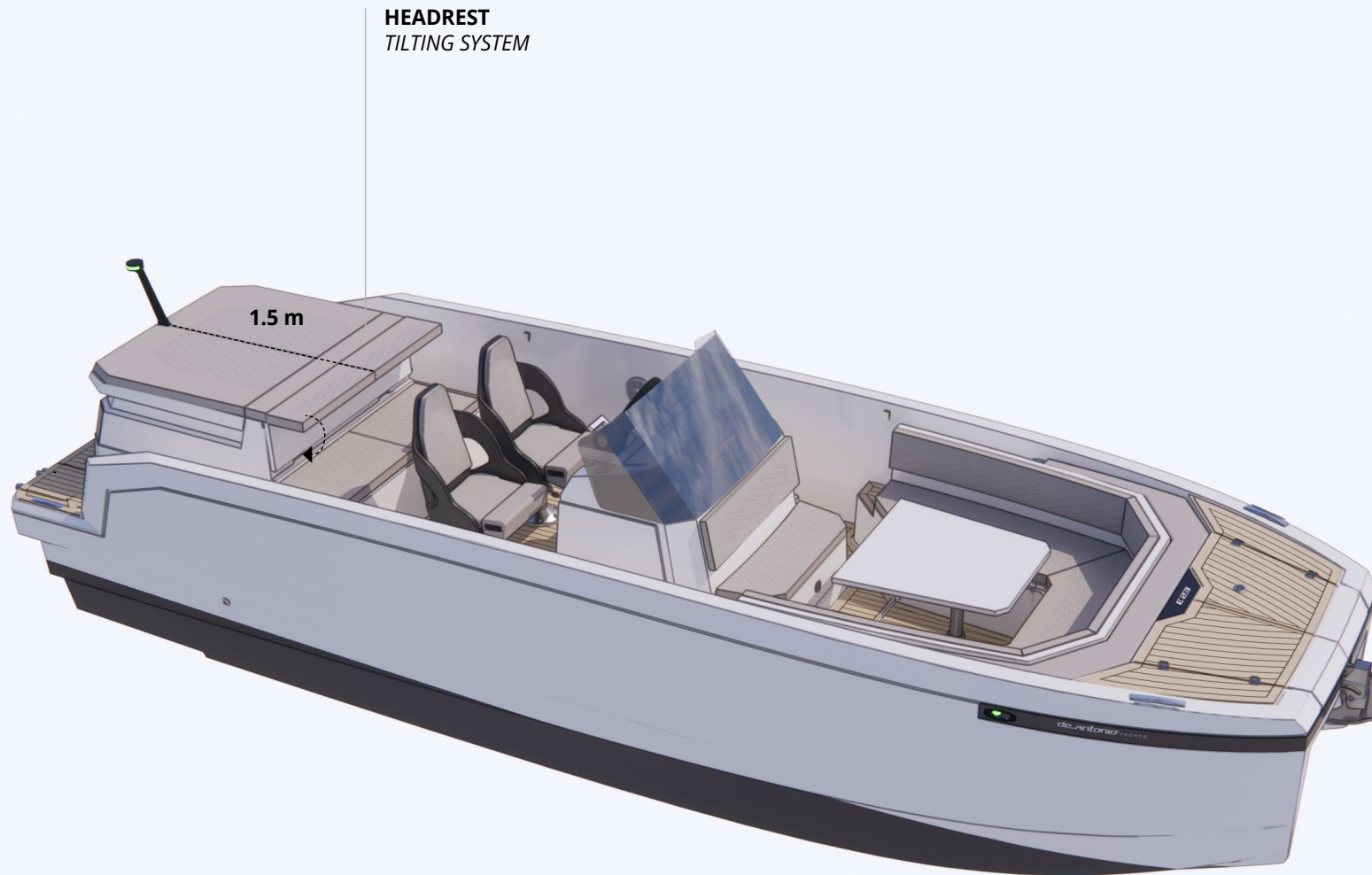

EXTENDED STERN SOLARIUM MODE

# FENDERING

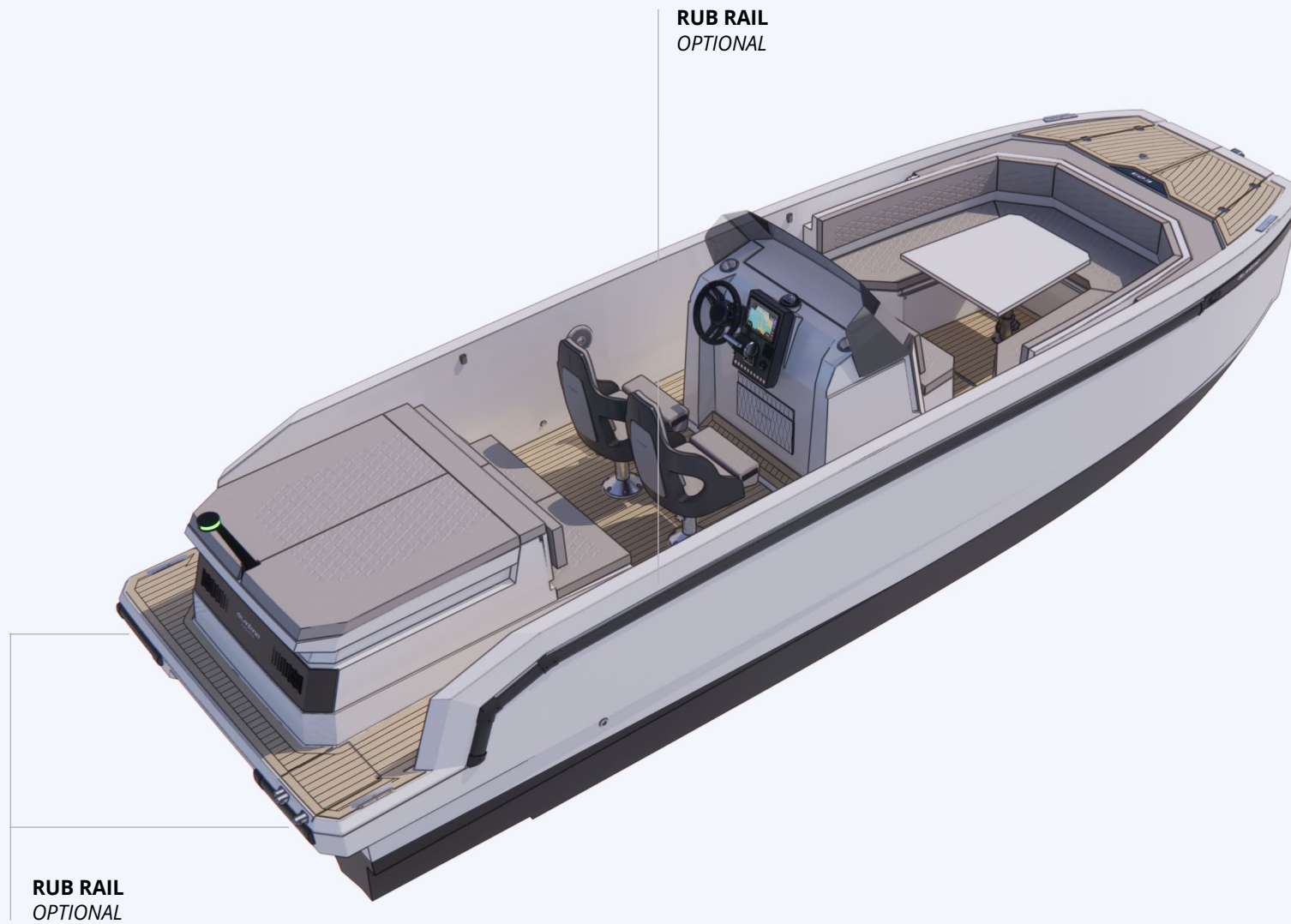

NEW **E23**

# ENGINE MODULE



NEW **E23**

# ENGINE ROTATION

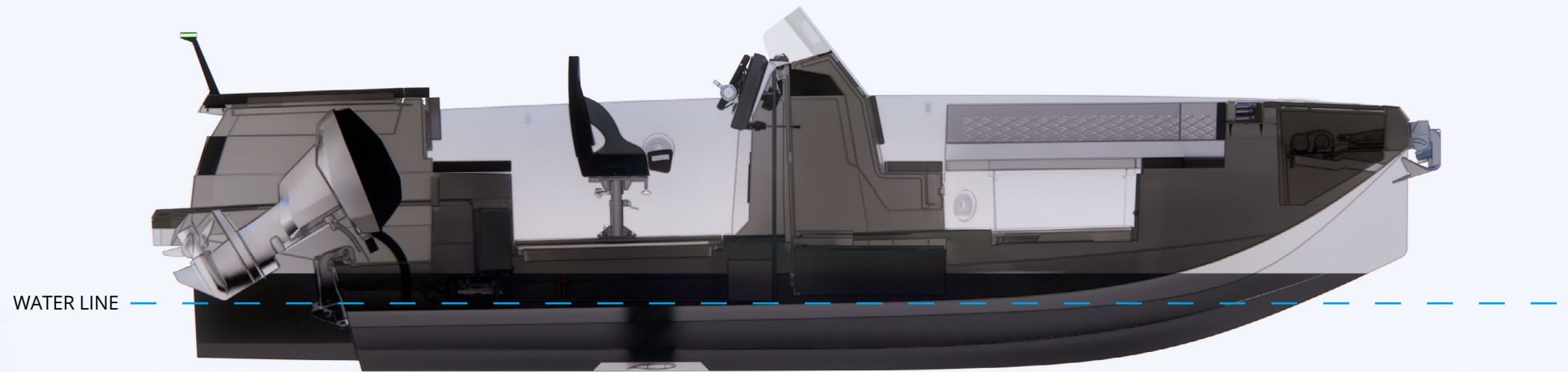

NEW **E23**



**SOFT TOP**



*NEW* **E23**

# FULL CANVAS AWNING

**CANVAS**  
*UV PROTECTION*

**CARBON POLES**  
*X4 FOLDABLE*



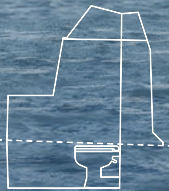

**STORAGE CABIN  
WC OPTIONAL**

CABINA DE ALMACENAJE  
INODORO OPCIONAL



**HIDDEN ELECTRIC  
OUTBOARD ENGINE**

MOTOR ELÉCTRICO  
FUERABORDA OCULTO



**INTEGRATED  
FOIL**

FOIL INTEGRADO



OFFICIAL ELECTRIC BOAT OF 37TH AMERICA'S CUP

*de antonio*  
YACHTS

*POWERED BY INNOVATION*